

CD STUD WELDING ACCESSORIES **"A" COLLETS**

GUN SHAFT INTERNAL STOPS & HOLDER

These stops are used with "THRU" Collet Inserts and "B" Collets for long length weld pins or studs. These stops are held in place inside the ID of the CD gun shaft with a stop holder and requires partial disassembly of the gun for installation. These stops can be installed by special order when purchasing a CD gun or can be installed in the field.



Holder

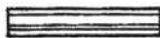

Stop

STOP DIA. X DEPTH	PART NO.
1/4 x 1/2	036-549
1/4 x 1"	037-829
1/4 x 1-1/2	037-000
1/4 x 2"	044-310
1/4 x 2-1/2	037-002
1/4 x 3"	037-003
STOP HOLDER	033-680

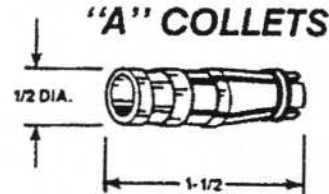
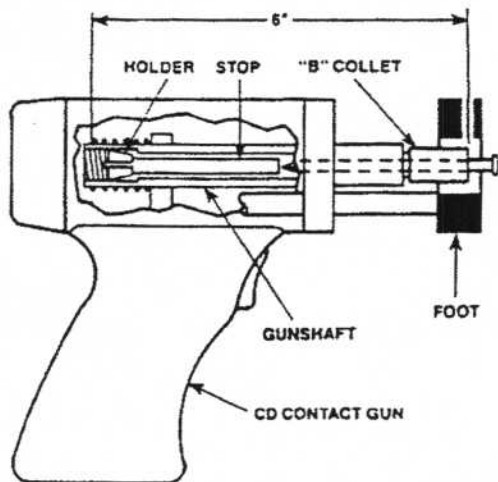

"A" STOPS



"A" collets and stops for production welding equipment with 1/2" ID gun shafts are available.

ONE PIECE CONTACT/MAGNETIC CUP HEAD CHUCK

For welding mild steel Cup Head Pins with CD contact gun.

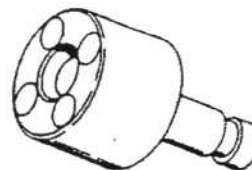

CUP HEAD SIZE	PART NO.
CS & CL	039-613

All information contained herein subject to change without notice.

ACC-3

NEW-AGE FASTENING SYSTEMS, INC.

Studwelding Equipment, Fasteners & Supplies
 Boiler Outage Specialists
 Jobsite Studwelding Division
 P.O. Box 5658, Deptford, NJ 08096
 Phone: (856) 218-8301
 Fax: (856) 218-8305
 Toll Free: (888) 889-3833
 steve@newagestudwelding.com