

NEW-AGE

FASTENING SYSTEMS, INC.

Featuring New technology and options for

Industrial Wear Control

Tuffstudds®



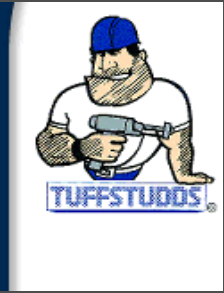

Tuffstudds®



OVERVIEW

- An innovative approach for applying wear studs on areas exposed to high abrasion.
- **State of the art** hardfacing technology
- **Tuffstudds** are carbide-laden, wear resistant alloy studs
>RC hardness is between 50-60
- Tightly applied patterns create a “**dead bed**” effect which further enhances wear resistance.
- Applied via **Arc Weld** onto alloy castings or plate
- Especially designed for heavy mining or construction operations.

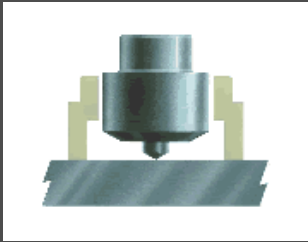

Tuffstudds®



Benefits

Convenience:

- Simple controls, automatic sequencing of the welding cycle
- Smokeless operation
- Horizontal, vertical and overhead position capability
- Minimal distortion due to heat build-up
- Repair capability on previously studded surfaces

Speed:

- Application rates of up to **four** sq ft per hour *
- Deposit rates over 20 pounds per hour.*

* rates are dependent on coverage surface area and stud size

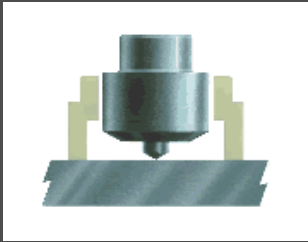

Tuffstudds®



Benefits

Long Life:

- Up to three times longer life reduces equipment downtime and overall costs of replaceable components.

Savings:

- Less Equipment Costs
- Less Downtime
- Less Labor Expense on repair and idle time
- Less overall cost for replacement parts

The **Tuffstudds Wear Protection System**
SAVES money and **INCREASES** your bottom line!!!

Tuffstudds®

Applications

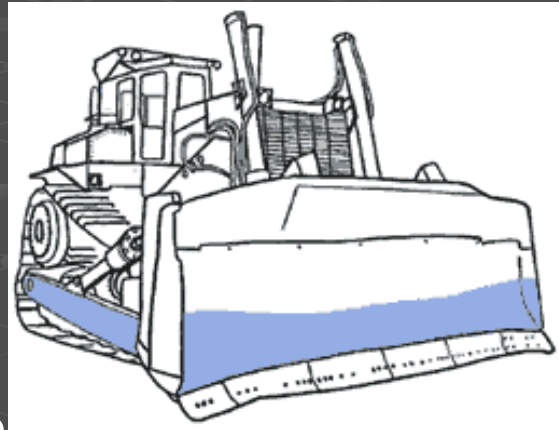

DOZER BLADES

- Proven method of protecting dozer blades.
- Applied to blades and push arms
- Multiple applications on original wear plate.
- Pattern becomes embedded with mineral debris creating dead bed effect

Tuffstudds® Applications



Packer Tips

- Effective method of protecting packer tips and blades.
- Tips retain packing edge longer, allowing more effective packing action.
- Wear on blades is minimized increasing life of part

Tuffstudds®

Applications

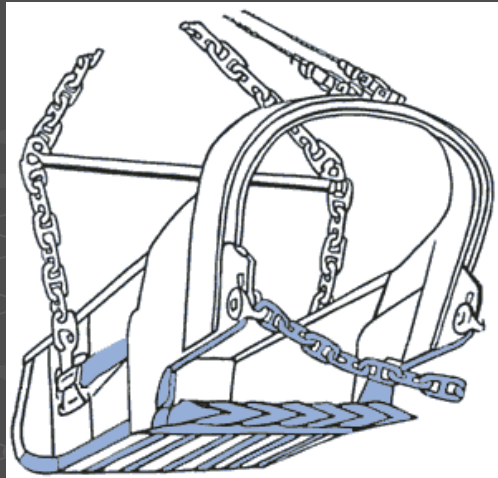

DRAGLINE BUCKETS

- protect worn bucket components.
- Wing shrouds and drag hitch areas all benefit from **Tuffstudd** protection.

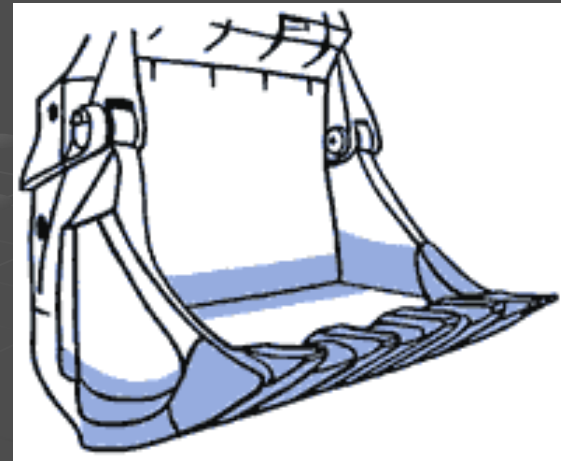

SHOVEL BUCKETS

- excellent wear protection for all types of shovel buckets.
- High-wear areas such as lips, cutting edges and tooth adaptors attain maximum life when protected with **Tuffstudds**.

Tuffstudds®

Misc. Applications



Augur Flights Edges



Compactor Wheels



Cage Mills Breaker Plates



Grapple Clam Tips/Arms

Tuffstudds®

Specifications

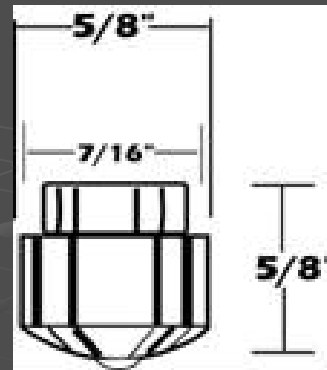

Specifications

- Tuffstudds are available in 3 different sizes
 - 5/8", 3/4" and 7/8" diameters.
- Tuffstudds are graded in 2 different grading to maximize performance
 - (I) for low impact, high abrasive conditions
 - (A) for higher impact conditions.
- Application speeds of up to 200 studs per hour.
- Best results occur by tightly packing Tuffstudds in patterns that minimize "wash-out" between stud rows.



Authorized Distributor for

Tuffstudds®

For **Product Demo** at your site or for additional information on Tuffstudds please contact:

CONTACT INFORMATION

- Sales Manager: Steve Swartz
- E-mail: steve@newagestudwelding.com
- Phone: 888-889-3833
- Fax: 856-218-3805
- Office Location:
 - 2 Enterprise Court
 - Sewell, NJ 08080