

STANDARD THREAD

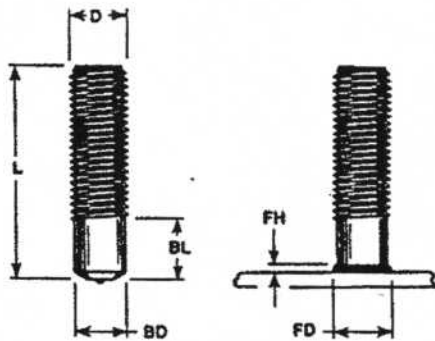

STUD						
D	MIN L	MIN BD	MIN BL	FD	FH	FERRULE CODE
1/4	3/4	.215	.375	.312	.093	P250
5/16	3/4	.275	.375	.406	.109	P312
3/8	3/4	.330	.390	.468	.109	P375
7/16	3/4	.387	.437	.531	.125	P347
1/2	7/8	.446	.500	.593	.156	P500
5/8	1	.562	.625	.750	.187	P625
3/4	1-1/4	.680	.796	.920	.250	P750
7/8	1-3/8	.798	.859	1.046	.312	P875
1"	1-1/2	.913	.921	1.187	.375	P1000

THREADS: Standard thread is UNC-2A (Rolled when possible), other threads are available upon request. Maximum standard thread length is 3-7/8".

MATERIAL:	LOW CARBON STEEL	STAINLESS STEEL
	C-0.23% max. P-0.04% max. Mn-0.90% max. S-0.05% max.	AISI grade - 302/304/305 std. Other grades available upon request.
MECHANICAL PROPERTIES:	Tensile	60,000 psi (min.)
	Yield	50,000 psi (min.)
	Elongation	20% (in 2 inches)
Values for various grades available upon request.		
PLATING:	Plating is not standard. Cadmium, copper nickel, and zinc available upon customer request.	Does not apply to Stainless.

FERRULES: Ferrules are component parts of studs. Not sold separately.

FERRULE

CODE	B	D	E	M	PART NO.
P250	.380	.455	.125	.250	092 0008 06
P312	.445	.535	.125	.250	092 0008 07
P375	.505	.595	.125	.265	092 0008 08
P437	.585	.675	.156	.329	092 0008 09
P500	.650	.740	.156	.362	092 0008 10
P625	.785	.906	.156	.433	092 0008 11
P750	1.030	1.150	.187	.526	092 0008 12
P875	1.203	1.330	.187	.593	092 0008 13
P1000	1.406	1.500	.187	.593	092 0008 14

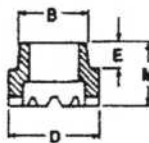

TO ORDER OR SPECIFY GIVE:

1. Product Code ARC ST
2. Diameter D
3. Length L
4. Material



Studwelding Equipment, Fasteners & Supplies
 Boiler Outage Specialists
 Jobsite Studwelding Division
 P.O. Box 5658, Deptford, NJ 08036
 Phone: (856) 218-8301
 Fax: (856) 218-8305
 Toll Free: (888) 889-3833
 steve@newagestudwelding.com

All information contained herein subject to change without notice.